

**DIECI**  
AMERICAS  
TELEHANDLERS



**ICARUS DYNAMIC**

**40.14 | 45.17 | 60.18**



**[dieci-americas.com](http://dieci-americas.com)**

## PERFORMANCE

Vehicle model	ICARUS 40.14 DYNAMIC - GD	ICARUS 45.17 DYNAMIC - GD	ICARUS 60.18 DYNAMIC - GD
Maximum capacity	8500 lb (3856 kg)	9900 lb (4491 kg)	13200 lb (5987 kg)
Maximum lifting height	44.0 ft (13.4 m)	53.8 ft (16.4 m)	58.4 ft (17.8 m)
Maximum horizontal extension	31.2 ft (9.5 m)	41 ft (12.5 m)	45.6 ft (13.9 m)
Fork swiveling angle	130°	130°	133°
Pull-out force	22031 lbf (9800 daN)	22031 lbf (9800 daN)	12814 lbf (5700 daN)
Towing force	19244 lbf (8560 daN)	19244 lbf (8560 daN)	21941 lbf (9760 daN)
Unladen weight	26676 lb (12100 kg)	28660 lb (13000 kg)	32518 lb (14750 kg)
Maximum climb angle	40 %	50 %	40 %
Max speed (referred to wheels with maximum permitted diameter)	23.6 mph (38 km/h)	23.6 mph (38 km/h)	18.6 mph (30 km/h)

## BOOM

Vehicle model	ICARUS 40.14 DYNAMIC - GD	ICARUS 45.17 DYNAMIC - GD	ICARUS 60.18 DYNAMIC - GD
Getting off the basket	8.4 s	10.2 s	9.3 s
Lifting	12.3 s	14.1 s	13.3 s
Extension	21.4 s	21.4 s	19 s
Retraction	15.6 s	14.1 s	12.8 s
Forward swiveling	3.3 s	3.3 s	3.3 s
Reverse swiveling	2.1 s	2.1 s	2.1 s

## ENGINE

Vehicle model	ICARUS 40.14 DYNAMIC - GD	ICARUS 45.17 DYNAMIC - GD	ICARUS 60.18 DYNAMIC - GD
Brand	Kubota	Kubota	Kubota
Nominal power	114 HP (85.1 kW)	114 HP (85.1 kW)	114 HP (85.1 kW)
@rpm	2600 rpm	2600 rpm	2600 rpm
Peak power	114 HP (85 kW)	114 HP (85 kW)	114 HP (85 kW)
@rpm	2600 rpm	2600 rpm	2600 rpm
Operation	4-stroke	4-stroke	4-stroke
Injection	Electronic, Common Rail	Electronic, Common Rail	Electronic, Common Rail
Number and arrangement of cylinders	4, Vertical in line	4, Vertical in line	4, Vertical in line
Displacement	230 in <sup>3</sup> (3769 cm <sup>3</sup> )	230 in <sup>3</sup> (3769 cm <sup>3</sup> )	230 in <sup>3</sup> (3769 cm <sup>3</sup> )
Consumption	353.68 lb/Hp h (215 g/kWh)	353.68 lb/Hp h (215 g/kWh)	353.68 lb/Hp h (215 g/kWh)
@rpm	2600 rpm	2600 rpm	2600 rpm
Emission standards	Stage V	Stage V	Stage V
Exhaust gas treatment	DOC+DPF+SCR	DOC+DPF+SCR	DOC+DPF+SCR
Cooling system	Liquid	Liquid	Liquid
Intake	Turbocharger after-cooler	Turbocharger after-cooler	Turbocharger after-cooler
Air filter	Air pre-heating and air pre-filtering with dust separator	Air pre-heating and air pre-filtering with dust separator	Air pre-heating and air pre-filtering with dust separator

## TRANSMISSION

Vehicle model	ICARUS 40.14 DYNAMIC - GD	ICARUS 45.17 DYNAMIC - GD	ICARUS 60.18 DYNAMIC - GD
Transmission type	Electronically controlled hydrostatic Shift on Fly with gear shift in motion and ECO function	Electronically controlled hydrostatic Shift on Fly with gear shift in motion and ECO function	Electronically controlled hydrostatic Shift on Fly with gear shift in motion and ECO function
Hydraulic motor	Hydrostatic with continuous automatic adjustment	Hydrostatic with continuous automatic adjustment	Hydrostatic with continuous automatic adjustment
Reversal	With electronic control operated with vehicle in motion	With electronic control operated with vehicle in motion	With electronic control operated with vehicle in motion
Inching	With electronic pedal for controlled forward movement	With electronic pedal for controlled forward movement	With electronic pedal for controlled forward movement
Gearbox	2-speed with electronic servo-control "Shift on Fly" with gear shift in motion	2-speed with electronic servo-control "Shift on Fly" with gear shift in motion	2-speed with electronic servo-control "Shift on Fly" with gear shift in motion

## DIFFERENTIAL AXLES

Vehicle model	ICARUS 40.14 DYNAMIC - GD	ICARUS 45.17 DYNAMIC - GD	ICARUS 60.18 DYNAMIC - GD
Type of axles	2 steering, with 4 epicycloidal reduction gears	2 steering, with 4 epicycloidal reduction gears	2 steering, with 4 epicycloidal reduction gears
Type of steering	4 wheels / transversal / 2 wheels	4 wheels / transversal / 2 wheels	4 wheels / transversal / 2 wheels
Front axle	With transverse leveling device with control in the cab	With transverse leveling device with control in the cab	With transverse leveling device with control in the cab
Rear axle	Swinging	Swinging	Oscillating with automatic lock
Service braking	Oil bath with servo brake on front and rear axle with double hydraulic system	Oil bath with servo brake on front and rear axle with double hydraulic system	Oil bath with servo brake on front axle with double hydraulic system
Parking braking	Negative actuation with electrical control	Negative actuation with electrical control	Negative actuation with electrical control

## HYDRAULIC SYSTEM

Vehicle model	ICARUS 40.14 DYNAMIC - GD	ICARUS 45.17 DYNAMIC - GD	ICARUS 60.18 DYNAMIC - GD
Hydraulic pump type	Dual gear pump for power steering and movements	Dual gear pump for power steering and movements	Dual gear pump for power steering and movements
Hydraulic pump capacity	37.0 gal/min (140 l/min)	37.0 gal/min (140 l/min)	37.0 gal/min (140 l/min)
Max. operating pressure	3626 psi (25 MPa)	3626 psi (25 MPa)	3916 psi (27 MPa)
Distributor control	4 in 1 proportional electrical Joystick with FNR	4 in 1 proportional electrical Joystick with FNR	4 in 1 proportional electrical Joystick with FNR
Distributor type	4in1 full electric	Distributor 4in1 full electric	Distributor 4in1 full electric
Outriggers	Two with proportional control and independent from the cab	Two with proportional control and independent from the cab	Two with proportional control and independent from the cab

## FILLING

Vehicle model	ICARUS 40.14 DYNAMIC - GD	ICARUS 45.17 DYNAMIC - GD	ICARUS 60.18 DYNAMIC - GD
Hydraulic system (total)	45.97 gal (174 l)	45.97 gal (174 l)	50.19 gal (190 l)
Diesel tank	31.70 gal (120 l)	31.70 gal (120 l)	31.70 gal (120 l)
AdBlue tank	5.28 gal (20 l)	5.28 gal (20 l)	5.28 gal (20 l)

## TOWING CAPACITY

Vehicle model	ICARUS 40.14 DYNAMIC - GD	ICARUS 45.17 DYNAMIC - GD	ICARUS 60.18 DYNAMIC - GD
Unbraked trailer	6614 lb (3000 kg)	-	-
Inertia braking	13228 lb (6000 kg)	-	-

## TYRES

Vehicle model	ICARUS 40.14 DYNAMIC - GD	ICARUS 45.17 DYNAMIC - GD	ICARUS 60.18 DYNAMIC - GD
Standard tires	400/70-24	400/70-24	440/80-24"

## DIMENSIONS

Vehicle model	ICARUS 40.14 DYNAMIC - GD	ICARUS 45.17 DYNAMIC - GD	ICARUS 60.18 DYNAMIC - GD
A	15.4 in (390 mm)	15.4 in (390 mm)	18.1 in (460 mm)
B	74.8 in (1900 mm)	77.2 in (1960 mm)	87.8 in (2230 mm)
C	120.1 in (3050 mm)	120.1 in (3050 mm)	129.9 in (3300 mm)
D	49.4 in (1255 mm)	49.4 in (1255 mm)	53.9 in (1370 mm)
E1	110.4 in (2805 mm)	110.4 in (2805 mm)	115.6 in (2935 mm)
F	192.5 in (4890 mm)	192.5 in (4890 mm)	210.6 in (5350 mm)
G	244.1 in (6200 mm)	246.5 in (6260 mm)	271.7 in (6900 mm)
H	99.6 in (2530 mm)	99.6 in (2530 mm)	105.1 in (2670 mm)
I	37.8 in (960 mm)	37.8 in (960 mm)	37.8 in (960 mm)
L	77.6 in (1970 mm)	77.6 in (1970 mm)	80.7 in (2050 mm)
L1	249.6 in (6340 mm)	254.1 in (6455 mm)	279.3 in (7095 mm)
K01	32°	32°	30°
K03	10°	10°	10°
K06	147°	147°	145°
K07	14°	14°	14°
K08	120°	120°	120°
M	94.1 in (2390 mm)	94.1 in (2390 mm)	96.1 in (2440 mm)
M1	79.9 in (2030 mm)	79.9 in (2030 mm)	95.3 in (2420 mm)
O1	291.3 in (7400 mm)	293.9 in (7465 mm)	318.9 in (8100 mm)
P	55.3 in (1405 mm)	55.3 in (1405 mm)	49.2 in (1250 mm)
P1	2.0 in (50 mm)	2.0 in (50 mm)	2.4 in (60 mm)
Q	163.0 in (4140 mm)	163.0 in (4140 mm)	156.3 in (3970 mm)
Q1	47.2 in (1200 mm)	47.2 in (1200 mm)	60.0 in (1525 mm)
R	163.0 in (4140 mm)	163.0 in (4140 mm)	163.8 in (4160 mm)
R1	48.0 in (1220 mm)	48.0 in (1220 mm)	48.4 in (1230 mm)
S	70.9 in (1800 mm)	70.9 in (1800 mm)	84.7 in (2152 mm)
S1	4.7 in (120 mm)	4.7 in (120 mm)	5.1 in (130 mm)
T	6.1 in (155 mm)	3.9 in (98 mm)	3.1 in (80 mm)
T1	221.9 in (5635 mm)	223.4 in (5675 mm)	229.7 in (5834 mm)
U1	166.5 in (4230 mm)	168.3 in (4275 mm)	187.7 in (4767 mm)
V1	403.9 in (10260 mm)	407.9 in (10360 mm)	431.7 in (10965 mm)

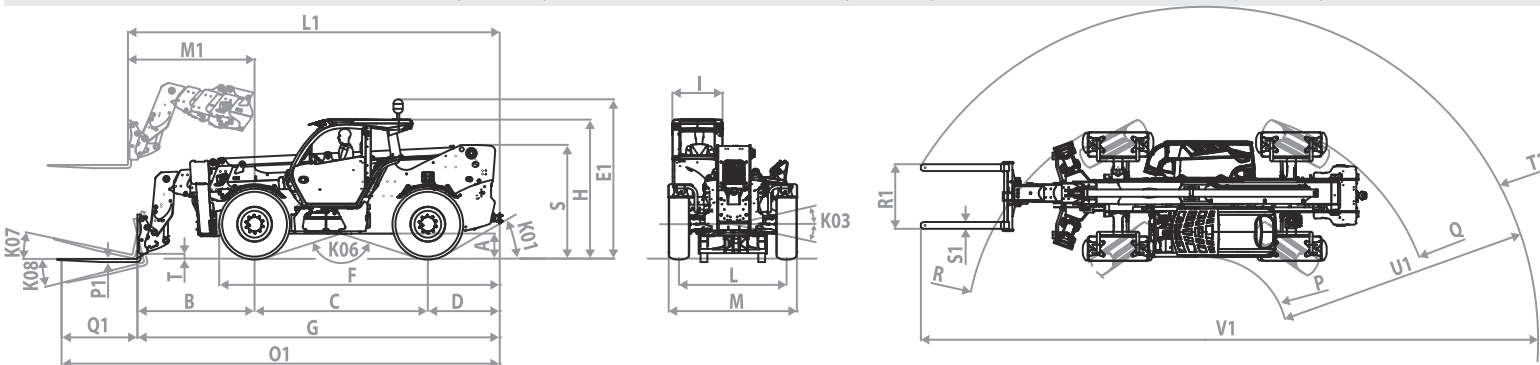

**MAX  
8800 lb**

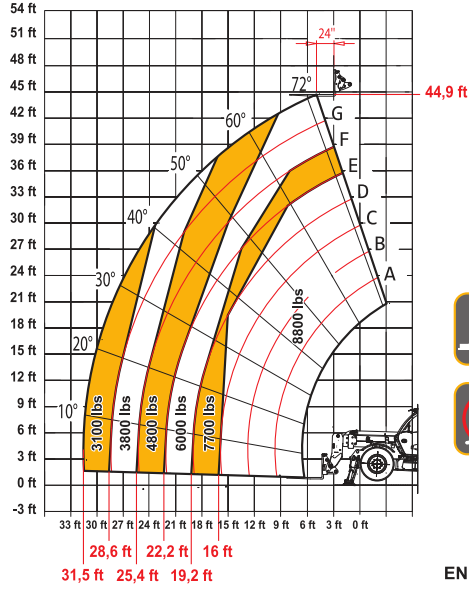

DOCDI0001314



EN1459-2

40.14

ON DEMAND

45.17

**MAX  
13200 lb**

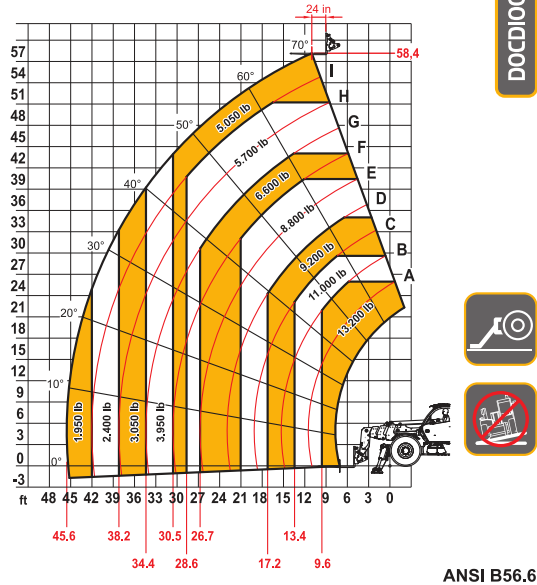

DOCDI0001827



ANSI B56.6

60.18