

DIECI
AMERICAS
TELEHANDLERS



AGRI PLUS

42.7 | 40.10



dieci-americas.com

PERFORMANCE

Vehicle model	AGRI PLUS 42.7 VS EVO2 - GD	AGRI PLUS 40.10 VS EVO2 - GD
Maximum capacity	9200 lb (4173 kg)	8800 lb (3992 kg)
Maximum lifting height	23.6 ft (7.2 m)	31.8 ft (9.7 m)
Maximum horizontal extension	12.5 ft (3.8 m)	19.7 ft (6.0 m)
Fork swiveling angle	146°	146°
Pull-out force	17985 lbf (8000 daN)	17985 lbf (8000 daN)
Towing force	20008 lbf (8900 daN)	20008 lbf (8900 daN)
Unladen weight	18739 lb (8500 kg)	20238 lb (9180 kg)
Maximum climb angle	45 %	45 %
Max speed (referred to wheels with maximum permitted diameter)	24.9 mph (40 km/h)	24.9 mph (40 km/h)

BOOM

Vehicle model	AGRI PLUS 42.7 VS EVO2 - GD	AGRI PLUS 40.10 VS EVO2 - GD
Getting off the basket	6.1 s	6.5 s
Lifting	6.9 s	7.4 s
Extension	5.8 s	8.4 s
Retraction	4.8 s	7.6 s
Forward swiveling	3 s	3 s
Reverse swiveling	2.6 s	2.6 s

ENGINE

Vehicle model	AGRI PLUS 42.7 VS EVO2 - GD	AGRI PLUS 40.10 VS EVO2 - GD
Brand	FPT	FPT
Nominal power	138 HP (103 kW)	138 HP (103 kW)
@rpm	2200 rpm	2200 rpm
Peak power	153 HP (114 kW)	153 HP (114 kW)
@rpm	1800 rpm	1800 rpm
Operation	4-stroke	4-stroke
Injection	4-Stroke Electronic Injection, Common Rail	4-Stroke Electronic Injection, Common Rail
Number and arrangement of cylinders	4, Vertical in line	4, Vertical in line
Displacement	274 in ³ (4485 cm ³)	274 in ³ (4485 cm ³)
Consumption	348.74 lb/Hp h (212 g/kWh)	348.74 lb/Hp h (212 g/kWh)
@rpm	2200 rpm	2200 rpm
Emission standards	Stage V	Stage V
Exhaust gas treatment	DOC+SCRoF (with AdBlue)	DOC+SCRoF (with AdBlue)
Cooling system	Liquid	Liquid
Intake	16-valve turbocharger with aftercooler	16-valve turbocharger with aftercooler
Air filter	Air pre-heating and air pre-filtering with dust separator	Air pre-heating and air pre-filtering with dust separator

TRANSMISSION

Vehicle model	AGRI PLUS 42.7 VS EVO2 - GD	AGRI PLUS 40.10 VS EVO2 - GD
Transmission type	Hydrostatic Vario System EVO2 electronically controlled with 2 hydrostatic motors with continuous automatic adjustment	Hydrostatic Vario System EVO2 electronically controlled with 2 hydrostatic motors with continuous automatic adjustment
Hydraulic motor	2 Hydraulic motors with continuous automatic adjustment	2 Hydraulic motors with continuous automatic adjustment
Reversal	With electronic control operated with vehicle in motion	With electronic control operated with vehicle in motion
Inching	With electronic pedal for controlled forward movement	With electronic pedal for controlled forward movement
Drive mode	Automotive, Eco, Loader, Creeper	Automotive, Eco, Loader, Creeper

DIFFERENTIAL AXLES

Vehicle model	AGRI PLUS 42.7 VS EVO2 - GD	AGRI PLUS 40.10 VS EVO2 - GD
Type of axles	2 steering, with 4 epicycloidal reduction gears	2 steering, with 4 epicycloidal reduction gears
Type of steering	4 wheels / transversal / 2 wheels	4 wheels / transversal / 2 wheels
Front axle	Rigid (Levelling upon request)	Leveling
Rear axle	Swinging	Swinging
Service braking	Oil bath with servo brake on front and rear axle with double hydraulic system	Oil bath with servo brake on front and rear axle with double hydraulic system
Parking braking	Negative actuation with electronic control	Negative actuation with electronic control

HYDRAULIC SYSTEM

Vehicle model	AGRI PLUS 42.7 VS EVO2 - GD	AGRI PLUS 40.10 VS EVO2 - GD
Hydraulic pump type	Piston pump with variable flow rate for power steering and movements. Gear pumps for Fan Drive with fan reversal.	Piston pump with variable flow rate for power steering and movements. Gear pumps for Fan Drive with fan reversal.
Hydraulic pump capacity	59.2 gal/min (224 l/min)	59.2 gal/min (224 l/min)
Max. operating pressure	3771 psi (26 MPa)	3771 psi (26 MPa)
Distributor control	4 in 1 proportional electrical Joystick with FNR	4 in 1 proportional electrical Joystick with FNR
Distributor type	Hydraulic in 4 sections with "Load Sensing" proportional electric control with "Flow Sharing", 4 simultaneous movements with independent maximum speed setting of each movement, continuous oil function on hydraulic sockets.	Hydraulic in 4 sections with "Load Sensing" proportional electric control with "Flow Sharing", 4 simultaneous movements with independent maximum speed setting of each movement, continuous oil function on hydraulic sockets.

FILLING

Vehicle model	AGRI PLUS 42.7 VS EVO2 - GD	AGRI PLUS 40.10 VS EVO2 - GD
Hydraulic system (total)	50.19 gal (190 l)	50.19 gal (190 l)
Diesel tank	46.23 gal (175 l)	46.23 gal (175 l)
AdBlue tank	9.25 gal (35 l)	9.25 gal (35 l)

TOWING CAPACITY

Vehicle model	AGRI PLUS 42.7 VS EVO2 - GD	AGRI PLUS 40.10 VS EVO2 - GD
Unbraked trailer	7055 lb (3200 kg)	7055 lb (3200 kg)
Inertia braking	17637 lb (8000 kg)	17637 lb (8000 kg)
Hydraulic/pneumatic braking	44092 lb (20000 kg)	44092 lb (20000 kg)

TYRES

Vehicle model	AGRI PLUS 42.7 VS EVO2 - GD	AGRI PLUS 40.10 VS EVO2 - GD
Standard tires	460/70xR24" (17.5LR24")	460/70xR24" (17.5LR24")

DIMENSIONS

Vehicle model	AGRI PLUS 42.7 VS EVO2 - GD	AGRI PLUS 40.10 VS EVO2 - GD
A	15.7 in (400 mm)	15.7 in (400 mm)
C	112.2 in (2850 mm)	112.2 in (2850 mm)
D	38.4 in (975 mm)	38.4 in (975 mm)
E1	105.1 in (2670 mm)	105.1 in (2670 mm)
F	175.4 in (4456 mm)	175.4 in (4456 mm)
G	201.1 in (5109 mm)	202.1 in (5133 mm)
H	96.5 in (2450 mm)	96.5 in (2450 mm)
I	37.8 in (960 mm)	37.8 in (960 mm)
L	71.7 in (1820 mm)	71.7 in (1820 mm)
K01	34°	34°
K03	9°	9°
K06	144°	144°
K07	16°	16°
K08	130°	130°
M	90.2 in (2290 mm)	90.2 in (2290 mm)
O1	248.4 in (6309 mm)	249.3 in (6333 mm)
P	43.6 in (1107 mm)	43.6 in (1107 mm)
P1	1.8 in (45 mm)	1.8 in (45 mm)
Q	147.8 in (3753 mm)	147.8 in (3753 mm)
Q1	47.2 in (1200 mm)	47.2 in (1200 mm)
R1	43.3 in (1100 mm)	43.3 in (1100 mm)
S1	4.7 in (120 mm)	4.7 in (120 mm)
T1	189.5 in (4813 mm)	190.3 in (4834 mm)
U1	145.9 in (3706 mm)	146.5 in (3721 mm)
V1	343.6 in (8727 mm)	344.7 in (8755 mm)

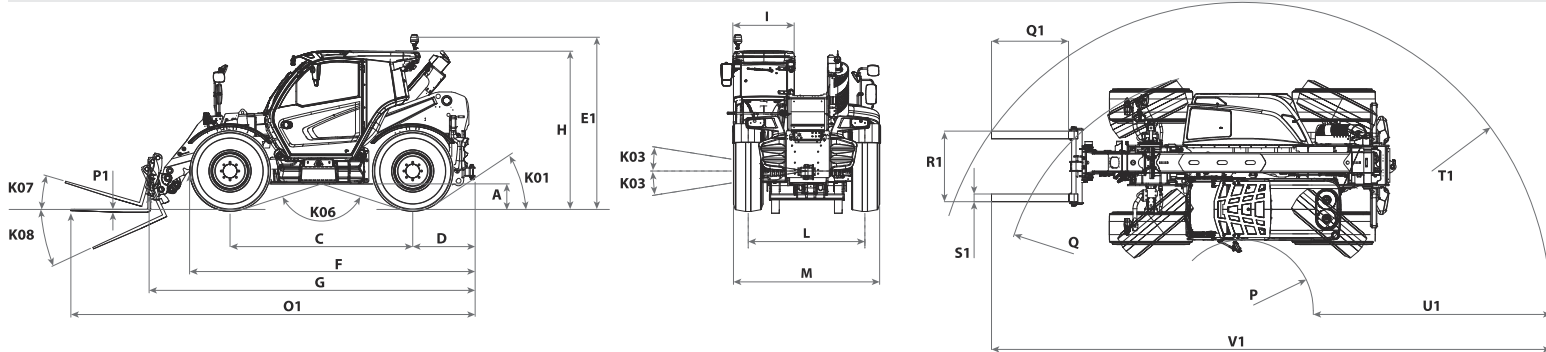

ON DEMAND

42.7

ON DEMAND

40.10