

# ICARUS DYNAMIC

40.14 | 45.17 | 60.18



**DIECI**



## CONTINUOUS EVOLUTION

Constantly ahead in terms of technological solutions, Dieci leads the evolutionary process of its vehicles, raising its standards with the **New Construction Range**.

**Reliability, efficiency and safety** are enhanced through the introduction of new technologies and instrumentation that take advantage of **technically advanced solutions**.

New stage V engines, **more intuitive and functional controls**, evolved diagnostics, **new chassis** and **new transmissions** bring tomorrow's telehandlers into the field today.

**Icarus Dynamic**, among Dieci's construction telehandlers, is the **high-height vehicle**: it can extend up to 18 meters, ensuring maximum stability through independent outriggers.

# ICARUS DYNAMIC

45.14 | 45.17 | 60.18

## PRACTICAL, EASY AND DYNAMIC

The new **Shift on Fly transmission** allows gear shift in motion directly from the joystick.

**High tilting force and proven reliability** thanks to the robust boom assembly.

**Electronically controlled boom suspension** significantly reduces oscillation.

Features that make it a dynamic, practical and easy-to-use machine that is **ideal for the rental market**.



### 45.14 ICARUS DYNAMIC

- Height 13.4 m
- Capacity 4500 kg

### 45.17 ICARUS DYNAMIC

- Height 16.4 m
- Capacity 4500 kg

### 60.18 ICARUS DYNAMIC

- Height 17.8 m
- Capacity 6000 kg

## TECHNOLOGICAL EFFICIENCY

- **Shift On Fly Transmission:** shifting gears without the need to stop.
- **Low consumption, high efficiency, optimized yield and maximum safety** in all the vehicle conditions of use.
- **ECO function:** maximum speed already at 2200 rpm, automatically managed by the control unit according to the power required by the operator.
- **Creeper Function:** adjustable forward speed with the accelerator pedal, constant engine speed and oil flow rate to effectively use equipment such as sweepers.

## PRACTICAL AND RELIABLE

- **Four driving wheels** and four steering wheels.
- **Three steering modes** which can be selected by the operator: concentric, front and crab.
- Hydraulic oil change every **2000 hours**.
- **Easy to reach filters** in the engine compartment.
- Sturdy and durable boom assembly: **tested reliability** for years of multiple applications and uses.
- **EN15000 anti-tipping system:** aggravating movements blocked in the event of overload and load level always in evidence.



## EASY AND INTUITIVE

- Travel direction and boom are controlled exclusively by the **new joystick**, which incorporates the direction selector (reverse shuttle - FNR) for intuitive, precise and comfortable control.
- The **advanced diagnostic system** provides information on the operation of the electronic control.
- Dashboard with clear instrument panel and **well-distributed controls**.
- **Arm too high function**: speed of travel limited automatically when the boom is raised.
- **Soft Motion System**: proportional and adjustable boom movements.

PROPORTIONALLY CONTROLLED INDEPENDENT OUTRIGGERS

TRANSVERSE LEVELING DEVICE



# COMFORT AND CONTROL

- **Giugiaro Design cab:** comfort with style in a clean and safe environment for the operator.
- **More legroom** for the operator.
- Adjustable steering column and armrest.
- **Three seat suspension systems** to choose from: mechanical, pneumatic and low frequency pneumatic.
- **Zero Shock System** shock-absorbing system.
- Soundproofing roof, dashboard and mat.
- Large windows.
- Integrated **LED work lights** for maximum visibility even at night: on the cab, boom and perimeter.
- Rear-view mirrors that allow all-round visibility and **optional cameras**.
- Vehicle information and diagnostic menu browsable in the **new 7" display**.



# VERSATILE AND FLEXIBLE

- The new Icarus Dynamic models have been designed to use the **various equipment** needed to carry out **all the work required** by a construction site: forks, loaders, lifting hooks, jibs with winches, grippers, material baskets, mixing buckets, concrete ladles, sweepers, salt spreader, snowplow blades.
- **Automatic equipment recognition:** the vehicle configures itself automatically recognizing the equipment attached.
- **Pre-arrangement for man basket:** the remote control allows the operator to operate the boom and the aerial platform directly from the basket, in total autonomy and full safety (complies with the EN 280 standard).

# TECHNICAL DATA

## PERFORMANCE

Vehicle model	ICARUS 45.14 DYNAMIC - GD	ICARUS 45.17 DYNAMIC - GD	ICARUS 60.18 DYNAMIC - GD
Maximum capacity	4500 kg (9921 lb)	4500 kg (9921 lb)	6000 kg (13228 lb)
Maximum lifting height	13,4 m (44,0 ft)	16,4 m (53,8 ft)	17,8 m (58,4 ft)
Maximum horizontal extension	9,5 m (31,2 ft)	12,5 m (41,0 ft)	13,9 m (45,6 ft)
Fork swiveling angle	130 °	130 °	133 °
Pull-out force	9800 daN (22031 lbf)	9800 daN (22031 lbf)	5700 daN (12814 lbf)
Towing force	8560 daN (19244 lbf)	8560 daN (19244 lbf)	9760 daN (21941 lbf)
Maximum climb angle	40 %	50 %	40 %
Unladen weight	12100 kg (26676 lb)	13000 kg (28660 lb)	14750 kg (32518 lb)
Max speed (referred to wheels with maximum permitted diameter)	38 km/h (23,6 mph)	38 km/h (23,6 mph)	30 km/h (18,6 mph)

## ENGINE

Vehicle model	ICARUS 45.14 DYNAMIC - GD	ICARUS 45.17 DYNAMIC - GD	ICARUS 60.18 DYNAMIC - GD
Brand	Kubota	Kubota	Kubota
Nominal power	85,1 kW (114 HP)	85,1 kW (114 HP)	85,1 kW (114 HP)
@rpm	2600 rpm	2600 rpm	2600 rpm
Peak power	85 kW (114 HP)	85 kW (114 HP)	85 kW (114 HP)
@rpm	2600 rpm	2600 rpm	2600 rpm
Displacement	3769 cm³ (230 in³)	3769 cm³ (230 in³)	3769 cm³ (230 in³)
Emission standard	Stage V	Stage V	Stage V
Exhaust gas treatment	DOC+DPF+SCR	DOC+DPF+SCR	DOC+DPF+SCR

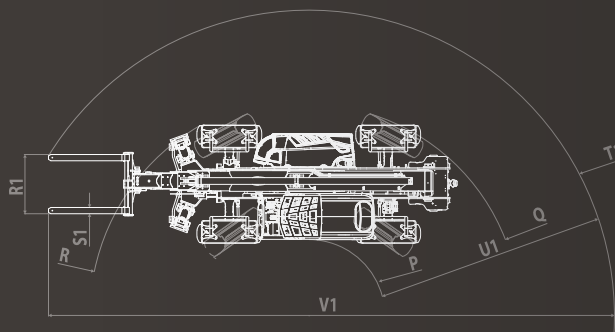
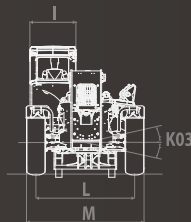
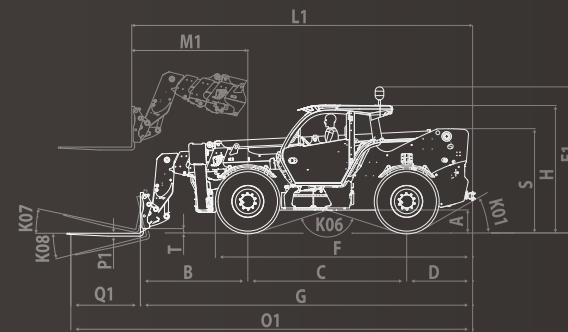

## HYDRAULIC SYSTEM

Vehicle model	ICARUS 45.14 DYNAMIC - GD	ICARUS 45.17 DYNAMIC - GD	ICARUS 60.18 DYNAMIC - GD
Hydraulic pump capacity	140 l/min (37,0 gal/min)	140 l/min (37,0 gal/min)	140 l/min (37,0 gal/min)
Max. operating pressure	25 MPa (3626 psi)	25 MPa (3626 psi)	27 MPa (3916 psi)

## DIMENSIONS

Vehicle model	ICARUS 45.14 DYNAMIC - GD	ICARUS 45.17 DYNAMIC - GD	ICARUS 60.18 DYNAMIC - GD
A	390 mm (15,4 in)	390 mm (15,4 in)	460 mm (18,1 in)
B	1900 mm (74,8 in)	1960 mm (77,2 in)	2230 mm (87,8 in)
C	3050 mm (120,1 in)	3050 mm (120,1 in)	3300 mm (129,9 in)
D	1255 mm (49,4 in)	1255 mm (49,4 in)	1370 mm (53,9 in)
E1	2805 mm (110,4 in)	2805 mm (110,4 in)	2935 mm (115,6 in)
F	4890 mm (192,5 in)	4890 mm (192,5 in)	5350 mm (210,6 in)
G	6200 mm (244,1 in)	6260 mm (246,5 in)	6900 mm (271,7 in)
H	2530 mm (99,6 in)	2530 mm (99,6 in)	2670 mm (105,1 in)
I	960 mm (37,8 in)	960 mm (37,8 in)	960 mm (37,8 in)
K01	32 °	32 °	30 °
K03	10 °	10 °	10 °
K06	147 °	147 °	145 °
K07	14 °	14 °	14 °
K08	120 °	120 °	120 °
L	1970 mm (77,6 in)	1970 mm (77,6 in)	2050 mm (80,7 in)
L1	6340 mm (249,6 in)	6455 mm (254,1 in)	7095 mm (279,3 in)
M	2390 mm (94,1 in)	2390 mm (94,1 in)	2440 mm (96,1 in)
M1	2030 mm (79,9 in)	2030 mm (79,9 in)	2420 mm (95,3 in)
O1	7400 mm (291,3 in)	7465 mm (293,9 in)	8100 mm (318,9 in)
P	1405 mm (55,3 in)	1405 mm (55,3 in)	1250 mm (49,2 in)
P1	50 mm (2,0 in)	50 mm (2,0 in)	60 mm (2,4 in)
Q	4140 mm (163,0 in)	4140 mm (163,0 in)	3970 mm (156,3 in)
Q1	1200 mm (47,2 in)	1200 mm (47,2 in)	1525 mm (60,0 in)
R	4140 mm (163,0 in)	4140 mm (163,0 in)	4160 mm (163,8 in)
R1	1220 mm (48,0 in)	1220 mm (48,0 in)	1230 mm (48,4 in)
S	1800 mm (70,9 in)	1800 mm (70,9 in)	2152 mm (84,7 in)
S1	120 mm (4,7 in)	130 mm (5,1 in)	130 mm (5,1 in)
T	155 mm (6,1 in)	98 mm (3,9 in)	80 mm (3,1 in)
T1	5635 mm (221,9 in)	5675 mm (223,4 in)	5834 mm (229,7 in)
U1	4230 mm (166,5 in)	4275 mm (168,3 in)	4767 mm (187,7 in)
V1	10260 mm (403,9 in)	10360 mm (407,9 in)	10965 mm (431,7 in)



SCAN THE QR CODE FOR COMPLETE AND UPDATED DATA



CLICK FOR COMPLETE AND UPDATED DATA



## DTS

The **Dieci Telematic System** allows the Dieci service team to interact with the vehicle remotely. It telematically collects and sends operational data for easier and more timely **monitoring, diagnostics and maintenance**. **Vehicle and operators protected from theft and accidents thanks to GSM and GPS connections.**

## DIECI SERVICE

General headquarters in Emilia Romagna - over 135,000 square meters and about 400 people employed - and 3 branches in Germany, United Kingdom, France: Dieci is present in over 70 Countries with an **extensive network of over 600 dealers** and authorized service centers.

**Dieci Service**, our global technical assistance service, is developed on this basis: our customers are assisted directly by specialized technicians and every request is satisfied in a very short time. Dieci Service, **within a few hours, can provide interventions and spare parts all over the world.**

Visit [www.dieci.com](http://www.dieci.com) to find the dealer closest to you.

**600 DEALERS**

**70 COUNTRIES**

**3 BRANCHES**





# ICARUS DYNAMIC

45.14 | 45.17 | 60.18

INVICTO

**DIECI**

[www.dieci.com](http://www.dieci.com)



Ph: masterservicelorenz.it